

PREINSTALLATION  
VORINSTALLATION

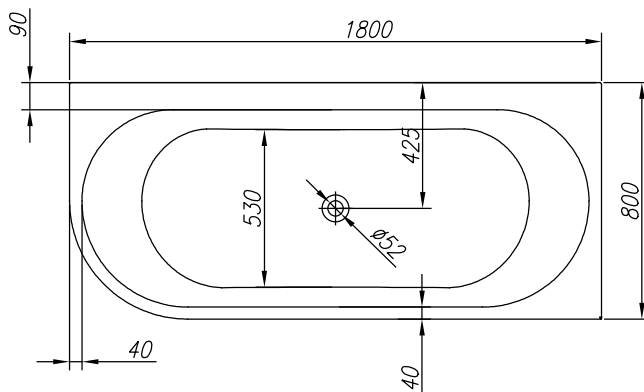
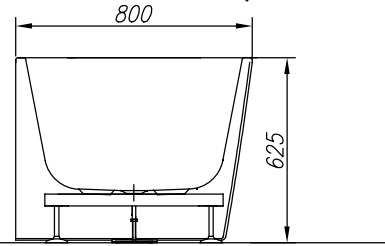
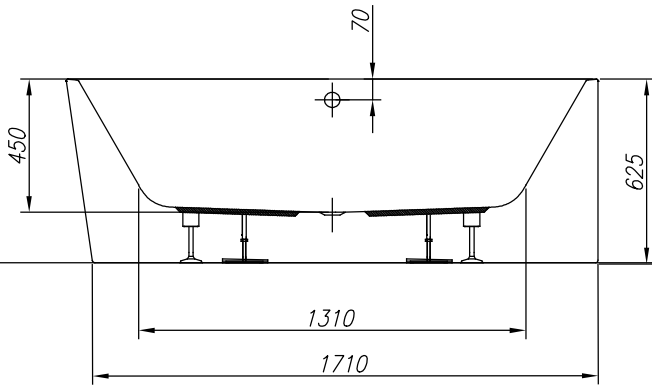
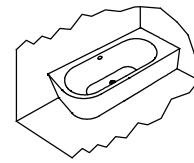

VOLUME (l)	MAX. LOAD (kg)	FLOOR LOAD (kg/m <sup>2</sup> )
VOLUMEN (l)	MAX. BELASTUNG (kg)	BODENBELASTUNG (kg/m <sup>2</sup> )

245

400

280

- - Spot for el. cable 3×2.5mm<sup>2</sup>, length approx. 1m
- Platz Stromkabel 3 × 2,5 mm<sup>2</sup>, Länge cca. 1 m
- - Spot for el. cable 1×6mm<sup>2</sup> for earthing, length approx. 1.5m
- Platz Stromkabel 1 × 6 mm<sup>2</sup> für Erdung, Länge cca. 1,5 m
- ⏏ - Connection of hot and cold water 1/2" min 0.2Mpa, max 0.4Mpa
- Anschluss Warm- und Kaltwasser 1/2" min 0,2 Mpa, max 0,4 Mpa
- - Drain spot Ø 50mm
- Abflussplatz Ø 50 mm

INSTALLATION RECOMMENDATION  
MONTAGEEMPFEHLUNG

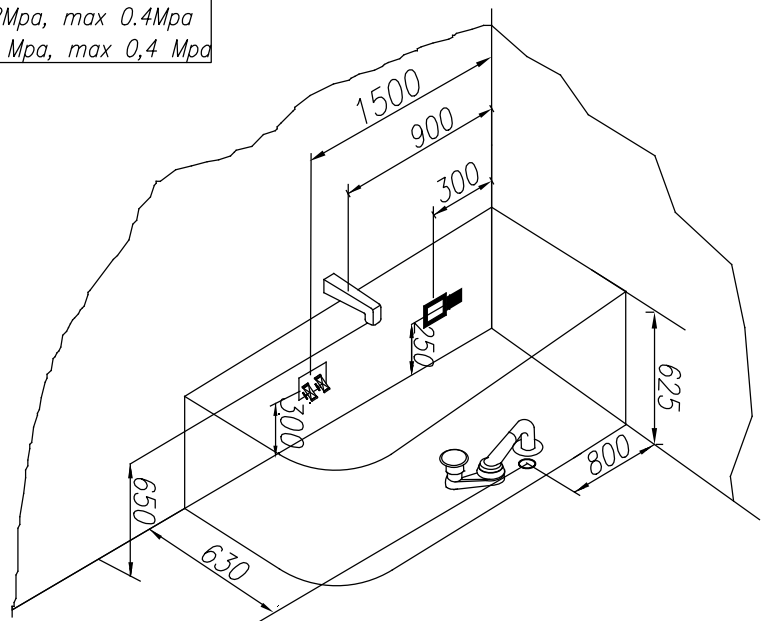

 - PUMP  
- WASSERPUMPE

 - WATER JETS  
- WASSERDÜSEN

 - AIR CONTROLLER  
- LUFTRGLER

 - ELECTRONIC SWITCHES  
- ELEKTROSCHALTER

 - FIXTURE AND SHOWER HANDLE  
- WASSERHAHN UND DUSCHE

 - BLOWER  
- LUFTPUMPE

 - AIR JET  
- LUFTDÜSE

 - PNEUMATIC SWITCH  
- PNEUMATIKSCHALTER

 - LIGHT OR CHROMOTHERAPY  
- LICHT- ODER CHROMOTHERAPIE

 - MICROJET SWITCH  
- SCHALTER FÜR MIKRODÜSEN

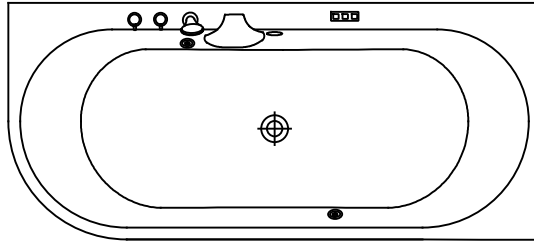

- OPTION FIXTURE AND SHOWER HANDLE - MÖGLICHKEIT WASSERHAHN UND DUSCHE

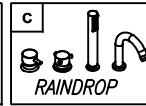
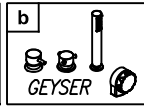
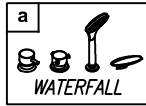
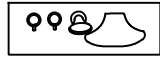

- OPTION CHROMOTHERAPY

- MÖGLICHKEIT CHROMOTHERAPIE

